

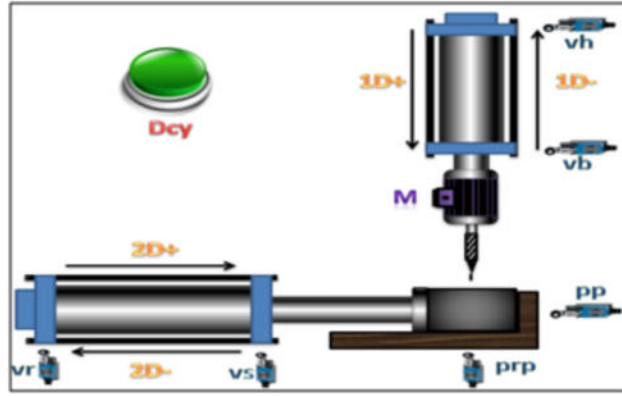

# هندسة ميكانيكية

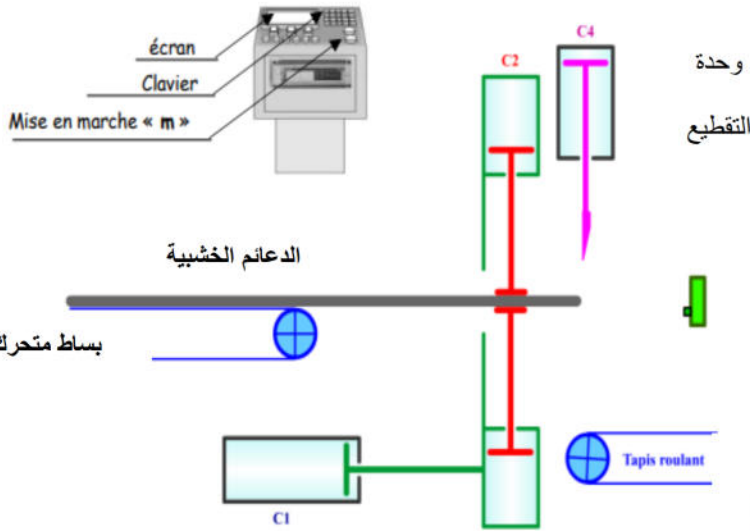

منصب  
التثبيت



## فرض للفصل الأول

الأستاذ : لعزاري مهدي

ثانوية : مبارك الملي - بوينان -

البلدية

الإسم : .....

اللقب : .....

القسم : .....

2022/. 2021

الوثيقة 1/.....

الموضوع : يمثل النظام المدروس وحدة آلية لتقطيع وتثقيب قوائم الرفوف الخشبية متعددة الاستعمال .

## وحدة آلية للتقطيع والتثقيب

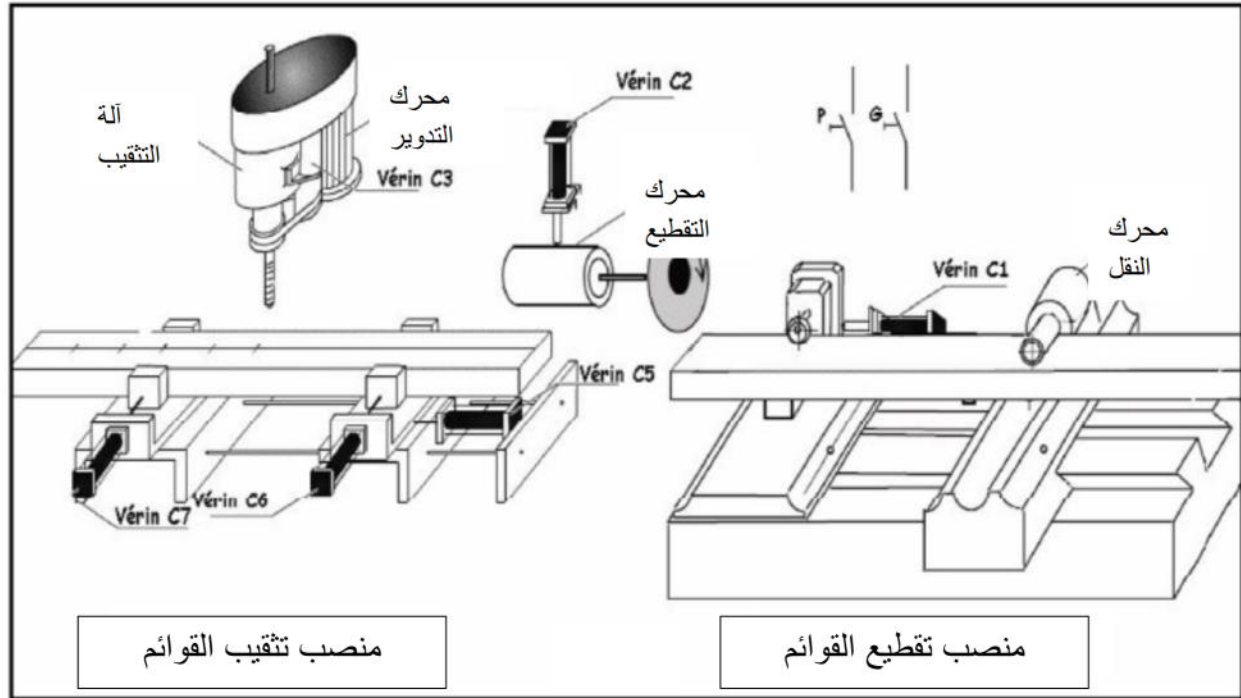

سير النظام :

النظام يتكون من:

• منصب التقطيع :

في هذه المرحلة يتم ضمان نقل القوائم بواسطة محرك النقل , أما التقطيع فيكون بواسطة قرص التقطيع المثبت على محرك التقطيع حسب أطوال مختلفة .

• منصب التثقيب : يتكون من :

- محرك تدوير الأداة ( M ) .

- دافعة C<sub>3</sub> تضمن نزول حامل الأداة .

- دافعة C<sub>5</sub> تضمن انتقال الملزمة المتحركة .

- دافعة C<sub>6</sub> تضمن شد وتفكيك الملزمة المتحركة .

- دافعة C<sub>7</sub> تضمن شد وتفكيك الملزمة الثابتة .

• منصب الإخلاء : يتم إخلاء وتخزين القوائم بحسب طولهم .

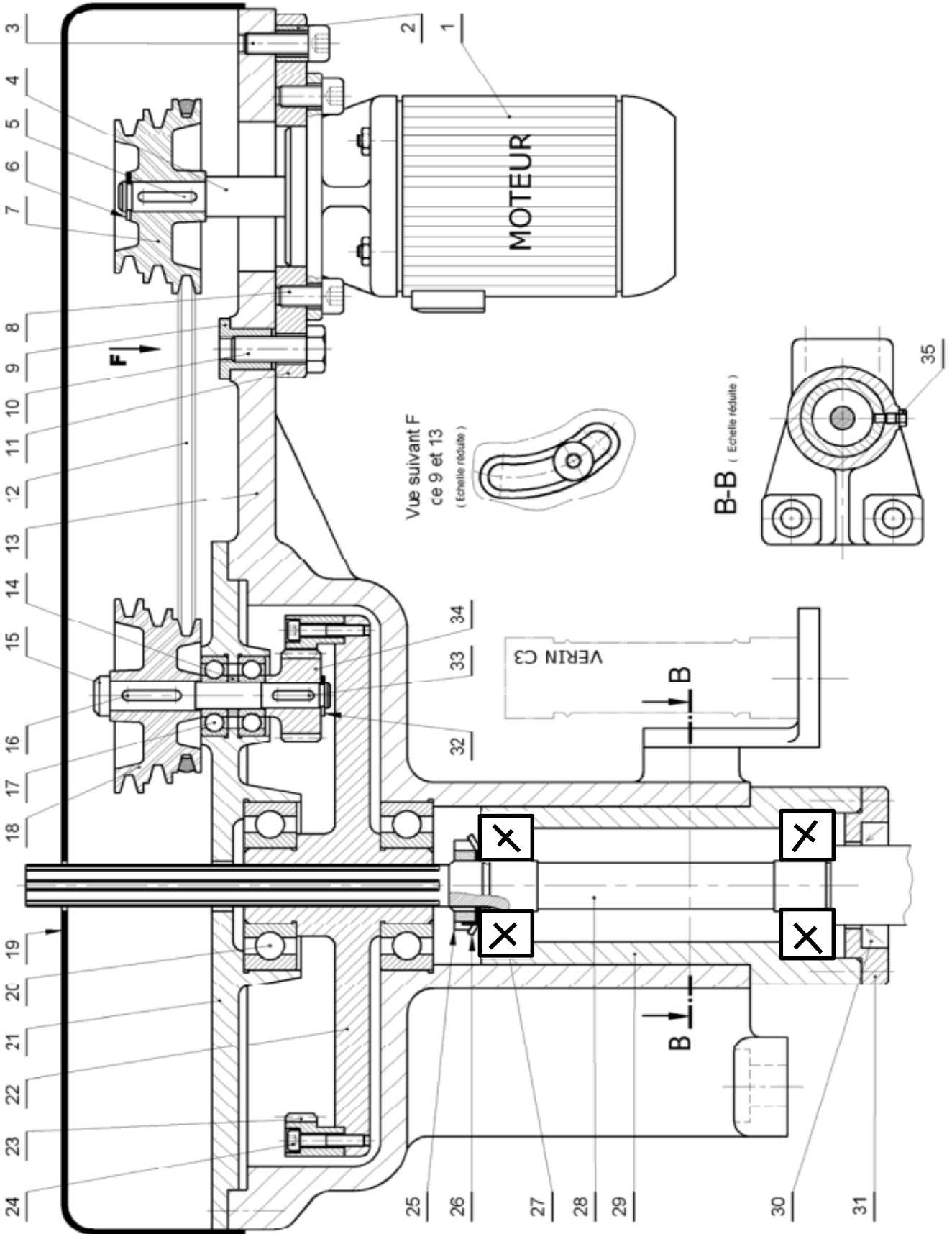

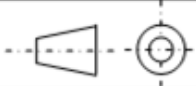
المقياس : 1:4	<b>منصب تنقيب</b>	اللغة Ar
		00
الصفحة 10/2		

ترس	1	34	مدرجة BC	2	17
خابور متوازي	1	33	خابور متوازي	1	16
حلقة مرتة	1	32	عمود وسيط	1	15
هيكل	1	31	فاصل	2	14
فاصل كتامة ذو شفة	1	30	جسم	2	13
عمد	1	29	سير	1	12
عمود	1	28	سند المحرك	1	11
مدرجة KB	2	27	يرشي H	1	10
حلقة كيج	1	26	صامولة	2	9
صامولة محززة	1	25	يرشي CHc	4	8
يرشي CHc	6	24	بكرة محرك	2	7
تاج	1	23	حلقة مرتة	1	6
جسم	1	22	خابور متوازي	1	5
غطاء	1	21	عمود محرك	1	4
مدرجة BC	1	20	يرشي CHc	2	3
هيكل	2	19	لجاف	4	2
بكرة مستقبلة	1	18	محرك M	1	1
التعيين	العدد	الرقم	التعيين	العدد	الرقم
المقاييس: 1:4	منصب تثقيب			اللغة	
				Ar	
الصفحة 10/3	3				

## ملف الموارد

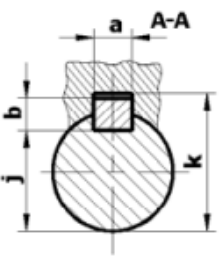
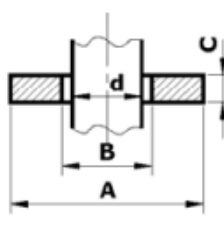
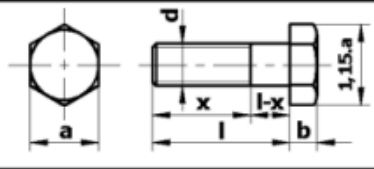
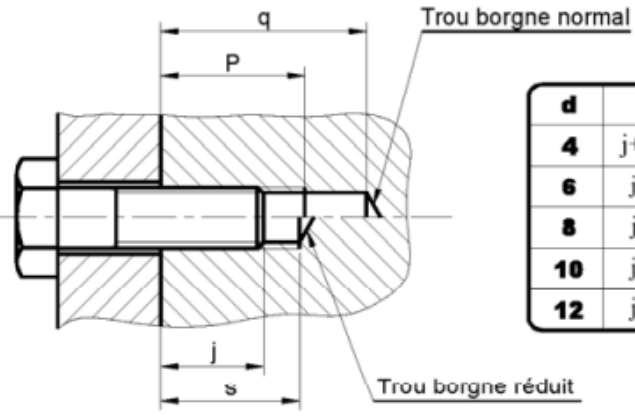
خابور متوازي		حلقة مسطحة																																																																																																															
	<table border="1" style="margin-left: auto; margin-right: auto;"> <thead> <tr> <th>d</th> <th>a</th> <th>b</th> <th>j</th> <th>k</th> </tr> </thead> <tbody> <tr> <td>de 6 à 8 inclus</td> <td>2</td> <td>2</td> <td>d - 1,2</td> <td>d + 1</td> </tr> <tr> <td>8 à 10</td> <td>3</td> <td>3</td> <td>d - 1,8</td> <td>d + 1,4</td> </tr> <tr> <td>10 à 12</td> <td>4</td> <td>4</td> <td>d - 2,5</td> <td>d + 1,8</td> </tr> <tr> <td>12 à 17</td> <td>5</td> <td>5</td> <td>d - 3</td> <td>d + 2,3</td> </tr> <tr> <td>17 à 22</td> <td>6</td> <td>6</td> <td>d - 3,5</td> <td>d + 2,8</td> </tr> <tr> <td>22 à 30</td> <td>8</td> <td>7</td> <td>d - 4</td> <td>d + 3,3</td> </tr> <tr> <td>30 à 38</td> <td>10</td> <td>8</td> <td>d - 5</td> <td>d + 3,3</td> </tr> </tbody> </table>	d	a	b	j	k	de 6 à 8 inclus	2	2	d - 1,2	d + 1	8 à 10	3	3	d - 1,8	d + 1,4	10 à 12	4	4	d - 2,5	d + 1,8	12 à 17	5	5	d - 3	d + 2,3	17 à 22	6	6	d - 3,5	d + 2,8	22 à 30	8	7	d - 4	d + 3,3	30 à 38	10	8	d - 5	d + 3,3		<table border="1" style="margin-left: auto; margin-right: auto;"> <thead> <tr> <th rowspan="2">d</th> <th colspan="4">A</th> <th colspan="2">B</th> <th rowspan="2">C</th> </tr> <tr> <th>Z</th> <th>M</th> <th>L</th> <th>LL</th> <th>U</th> <th>N</th> </tr> </thead> <tbody> <tr> <td>4</td> <td>8</td> <td>10</td> <td>14</td> <td>16</td> <td>4,25</td> <td>4,5</td> <td>0,8</td> </tr> <tr> <td>6</td> <td>12</td> <td>14</td> <td>18</td> <td>24</td> <td>6,25</td> <td>7</td> <td>1,2</td> </tr> <tr> <td>8</td> <td>16</td> <td>18</td> <td>22</td> <td>30</td> <td>8,25</td> <td>9</td> <td>1,5</td> </tr> <tr> <td>10</td> <td>20</td> <td>22</td> <td>27</td> <td>36</td> <td>10,25</td> <td>11</td> <td>2</td> </tr> <tr> <td>12</td> <td>24</td> <td>27</td> <td>32</td> <td>40</td> <td>12,50</td> <td>14</td> <td>2,5</td> </tr> <tr> <td>14</td> <td>27</td> <td>30</td> <td>36</td> <td>45</td> <td>14,50</td> <td>16</td> <td>2,5</td> </tr> <tr> <td>16</td> <td>30</td> <td>32</td> <td>40</td> <td>50</td> <td>16,50</td> <td>18</td> <td>3</td> </tr> </tbody> </table>	d	A				B		C	Z	M	L	LL	U	N	4	8	10	14	16	4,25	4,5	0,8	6	12	14	18	24	6,25	7	1,2	8	16	18	22	30	8,25	9	1,5	10	20	22	27	36	10,25	11	2	12	24	27	32	40	12,50	14	2,5	14	27	30	36	45	14,50	16	2,5	16	30	32	40	50	16,50	18	3
d	a	b	j	k																																																																																																													
de 6 à 8 inclus	2	2	d - 1,2	d + 1																																																																																																													
8 à 10	3	3	d - 1,8	d + 1,4																																																																																																													
10 à 12	4	4	d - 2,5	d + 1,8																																																																																																													
12 à 17	5	5	d - 3	d + 2,3																																																																																																													
17 à 22	6	6	d - 3,5	d + 2,8																																																																																																													
22 à 30	8	7	d - 4	d + 3,3																																																																																																													
30 à 38	10	8	d - 5	d + 3,3																																																																																																													
d	A				B		C																																																																																																										
	Z	M	L	LL	U	N																																																																																																											
4	8	10	14	16	4,25	4,5	0,8																																																																																																										
6	12	14	18	24	6,25	7	1,2																																																																																																										
8	16	18	22	30	8,25	9	1,5																																																																																																										
10	20	22	27	36	10,25	11	2																																																																																																										
12	24	27	32	40	12,50	14	2,5																																																																																																										
14	27	30	36	45	14,50	16	2,5																																																																																																										
16	30	32	40	50	16,50	18	3																																																																																																										
<b>Tête hexagonale</b> Symbole : H		طول الثقب المولب																																																																																																															
			<table border="1" style="margin-left: auto; margin-right: auto;"> <thead> <tr> <th>d</th> <th>p</th> <th>q</th> <th>s</th> </tr> </thead> <tbody> <tr> <td>4</td> <td>j+2,5</td> <td>j+6</td> <td>j+2,5</td> </tr> <tr> <td>6</td> <td>j+4</td> <td>j+10</td> <td>j+3,5</td> </tr> <tr> <td>8</td> <td>j+5</td> <td>j+12</td> <td>j+4</td> </tr> <tr> <td>10</td> <td>j+6</td> <td>j+14</td> <td>j+4,5</td> </tr> <tr> <td>12</td> <td>j+7</td> <td>j+16</td> <td>j+5</td> </tr> </tbody> </table>	d	p	q	s	4	j+2,5	j+6	j+2,5	6	j+4	j+10	j+3,5	8	j+5	j+12	j+4	10	j+6	j+14	j+4,5	12	j+7	j+16	j+5																																																																																						
d	p	q	s																																																																																																														
4	j+2,5	j+6	j+2,5																																																																																																														
6	j+4	j+10	j+3,5																																																																																																														
8	j+5	j+12	j+4																																																																																																														
10	j+6	j+14	j+4,5																																																																																																														
12	j+7	j+16	j+5																																																																																																														
<table border="1" style="margin-left: auto; margin-right: auto;"> <thead> <tr> <th>d</th> <th>4</th> <th>6</th> <th>8</th> <th>10</th> </tr> </thead> <tbody> <tr> <td>Pas</td> <td>0,7</td> <td>1</td> <td>1,25</td> <td>1,5</td> </tr> <tr> <td>a</td> <td>7</td> <td>10</td> <td>13</td> <td>17</td> </tr> <tr> <td>b</td> <td>2,8</td> <td>4</td> <td>5,5</td> <td>7</td> </tr> </tbody> </table>	d	4	6	8	10	Pas	0,7	1	1,25	1,5	a	7	10	13	17	b	2,8	4	5,5	7	<p style="text-align: right;">Trou borgne normal</p>																																																																																												
d	4	6	8	10																																																																																																													
Pas	0,7	1	1,25	1,5																																																																																																													
a	7	10	13	17																																																																																																													
b	2,8	4	5,5	7																																																																																																													
<table border="1" style="margin-left: auto; margin-right: auto;"> <thead> <tr> <th>Longueur l</th> <th colspan="2">Longueurs filetées x</th> </tr> </thead> <tbody> <tr> <td>10</td> <td></td> <td></td> </tr> <tr> <td>12</td> <td></td> <td></td> </tr> <tr> <td>16</td> <td>14</td> <td></td> </tr> <tr> <td>18</td> <td>14</td> <td></td> </tr> <tr> <td>20</td> <td>14</td> <td>18</td> </tr> </tbody> </table>	Longueur l	Longueurs filetées x		10			12			16	14		18	14		20	14	18	<p style="text-align: right;">Trou borgne réduit</p>																																																																																														
Longueur l	Longueurs filetées x																																																																																																																
10																																																																																																																	
12																																																																																																																	
16	14																																																																																																																
18	14																																																																																																																
20	14	18																																																																																																															

## 1 - التحليل الوظيفي

1- أتمم مخطط العلية A-0 لمنصب التنقيب .

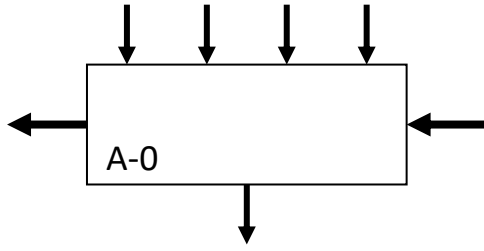

2- 2 - أكمل مخطط التحليل الوظيفي FAST الخاص بمنصب التنقيب .

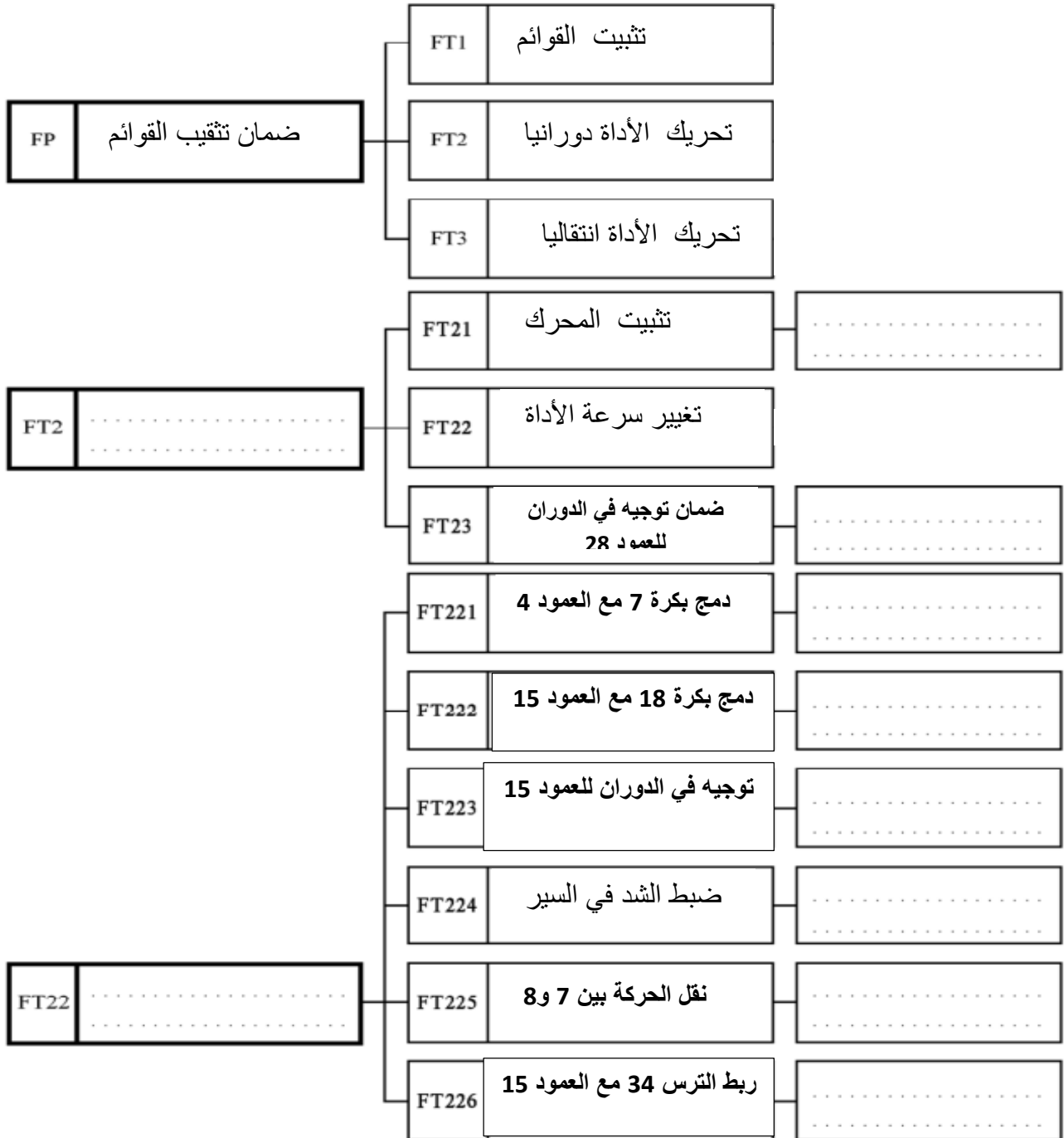

3- أتمم جدول الوصلات :

القطع	اسم الوصلة	الرمز	الحل التكنولوجي (الوسيلة)
07/04			
21/15			
(132 و 21)/22			
21/13			

4- أكمل الرسم التخطيطي الحركي لمنصب التنقيب .

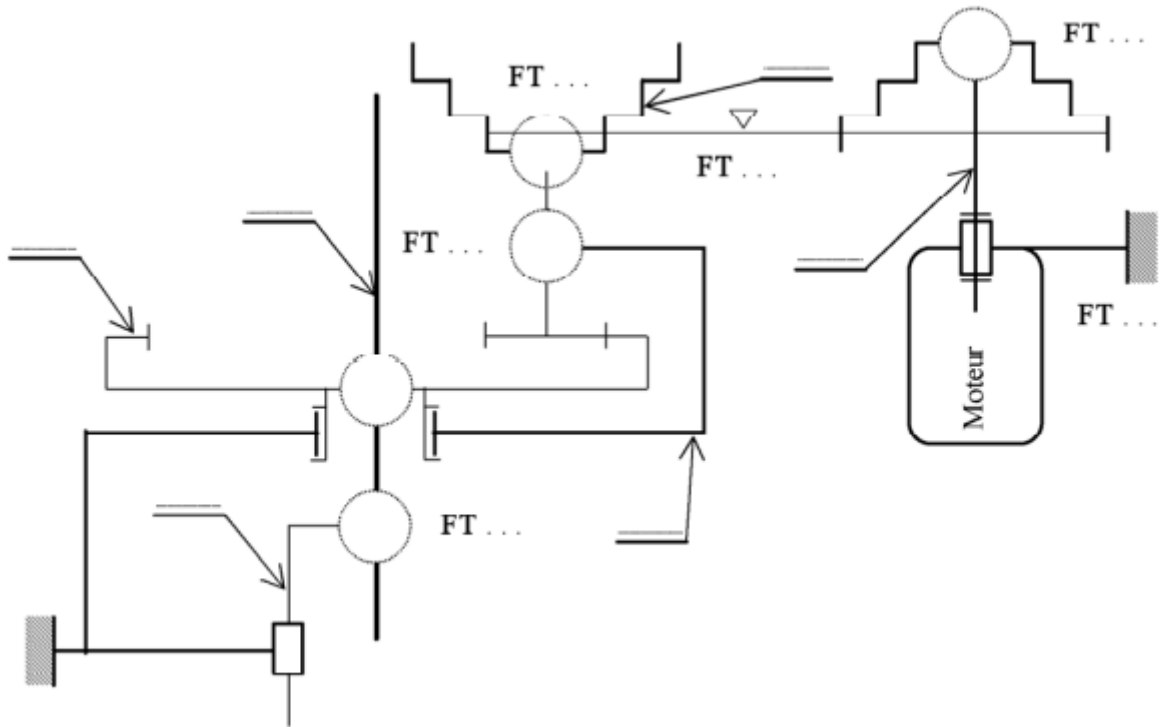

5- أتمم الجدول :

رقم القطعة	اسمها	وظيفتها
12		
05		
06		
26		
30		

6- من خلال الرسم ماهي مادة صنع القطع (7) و (18) ؟ برر هذا الاختيار .



7- على الرسم المقابل أنجز سلسلة الأبعاد الخاصة ببعء الشرط JA .

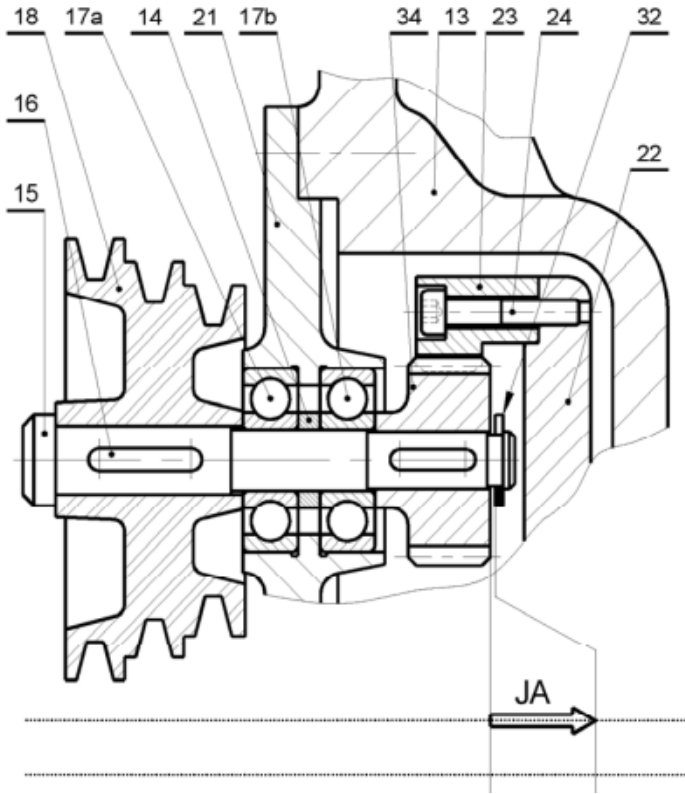

- برر وجود بعد الشرط JA .

- أحسب طول العمود (15) . علما أن :

$$A_{34} = 21^{+0,1}_0 ; A_{18} = 32^{+0,1}_0 , A_{05} = 1^{-0,06}_0$$

$$A_{17a} = A_{17b} = 10^{-0,15}_0 ; A_{14} = 4^{+0,05}_0$$

$$0,75 \leq JA \leq 1,55$$

8- التوافق بين الجلبة الداخلية للمدرجة (27) و العمود (28) هو  $\text{Ø}16 \text{ H}7\text{p}6$

$$\text{Ø}16 \text{ p}6 = \text{Ø}16^{+29}_{+18} \text{ و } \text{Ø}16 \text{ H}7 = \text{Ø}16^{+18}_0$$

أحسب هذا التوافق واستنتج نوعه

.....  
 .....

## 2 - التحليل البنوي

1 - وضح على الرسم وضعية الحواجز للجلبات الداخلية والخارجية للمدرجات (17) و (20) .

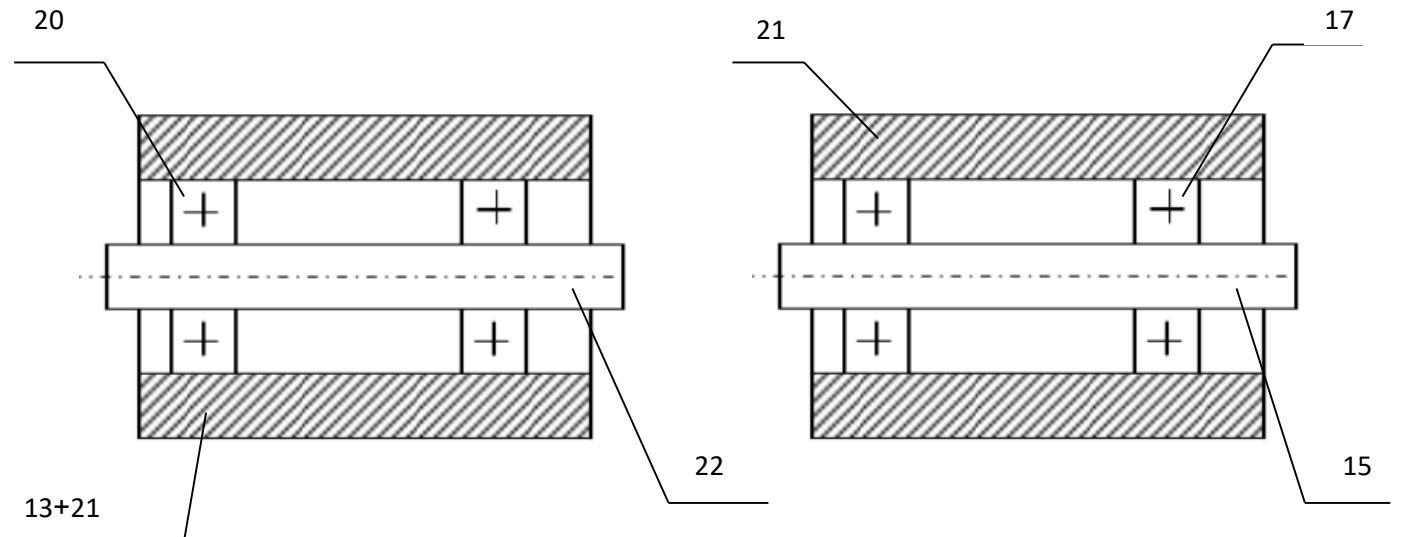



2- أقتراح المصمم تغيير الوصلة الإندماجية بين البكرة المستقبلية (7) والعمود (4).

وذلك باستعمال حلقة مسطحة وبرغي (H M10-25). اتمم الرسم بالاستعانة بملف الموارد

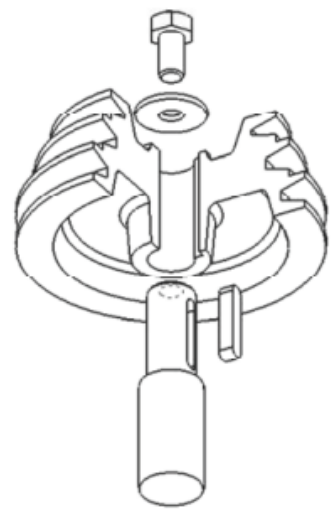
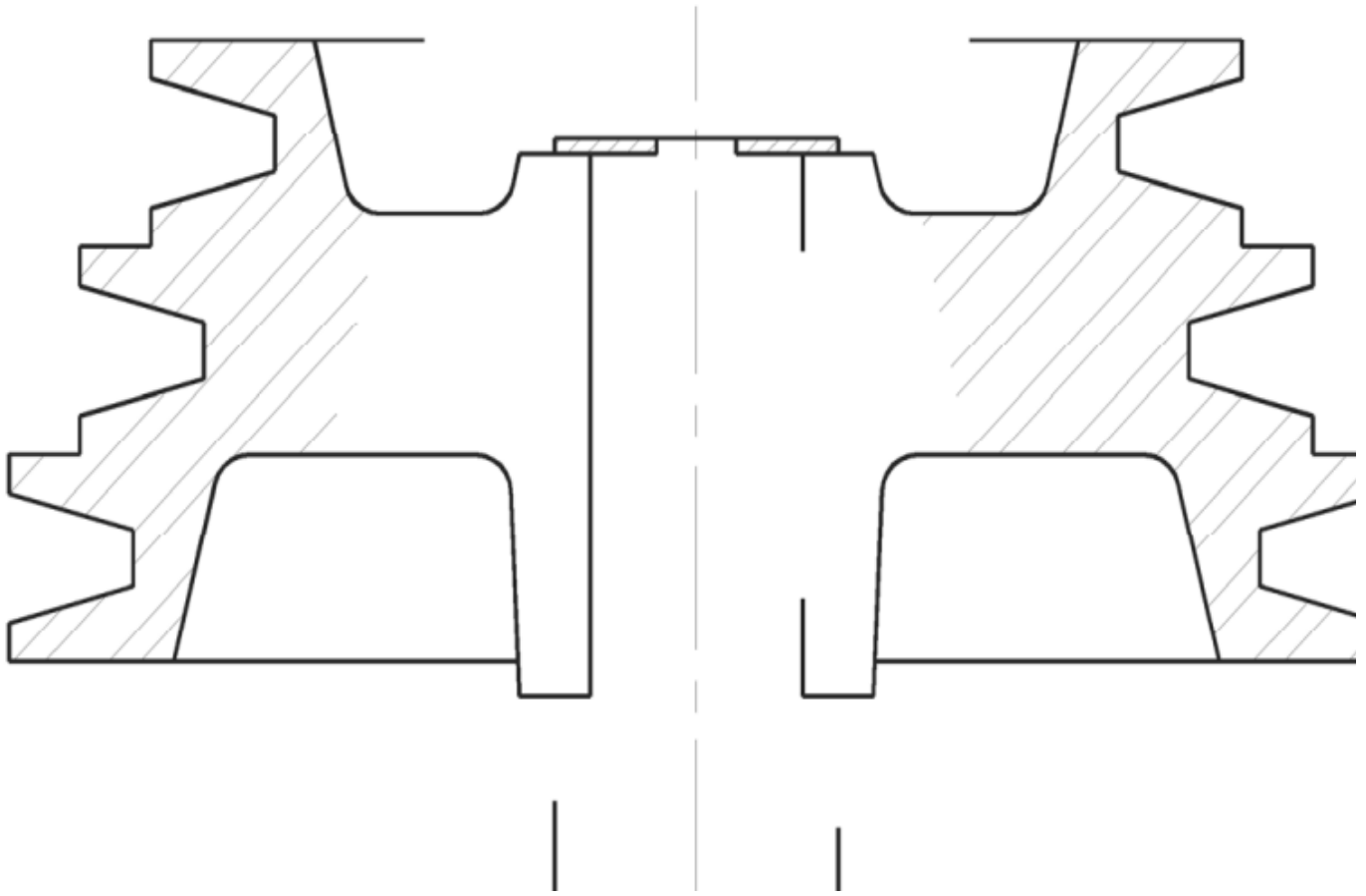

### 3-الأليات

من بين الدافعات المستعملة في هذا النظام دافعات بسيطة المفعول وأخرى مزدوجة المفعول .

1- أتمم تمثيل و ربط أجهزة للدارة الهوائية المكونة من:

\* دارة الاستطاعة (دافعة بسيطة المفعول +V موزع NF 3/2 أحادي الاستقرار يتحكم هوائي V)

\* دارة التحكم (موزع NF 3/2 بزر ضاغط)

حالة عمل

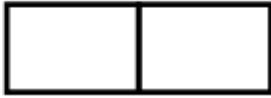

حالة راحة

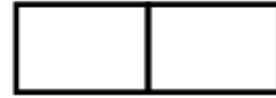
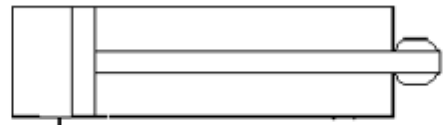

2- أتمم تمثيل و ربط أجهزة للدارة الهوائية المكونة من:

\* دارة الاستطاعة (دافعة مزدوجة المفعول + موزع NF 5/2 أحادي الإستقرار يتحكم هوائي)

\* دارة التحكم (موزع NF 3/2 بزر احتفاظ بالوضعية)

